

# Enclume



## Carrier Bag Rack LR10



Enclume hearth racks are the ultimate in Quality, design, strength and function. Congratulations for owning one of the finest Storage racks made.

**WARNING:**  
**READ ALL OF THE INSTRUCTIONS  
BEFORE ASSEMBLING AND USING  
YOUR RACK.**

Enclosed you will find everything needed for the assembly and use of your hearth rack. Two people make assembly and installation easier. The parts and hardware included are:

- |   |                                  |
|---|----------------------------------|
| 1-- Rack upright                              | 6—3/8" x 5/8" Button head screws |
| 2-- Long legs                                 | 1—7/32" Allen wrench             |
| 2 --Short legs                                | 4 –Hard floor glides             |
| 1 Cloth carrying bag (may be sold separately) |                                  |

### ASSEMBLY INSTRUCTIONS

- 1) Slip the floor glides over the ends of the short legs.
- 2) Place the two long legs over the top of and perpendicular to the two short legs. Attach them together with four of the button head screws. The screws should be inserted from the top down toward the floor. Tighten the screws only finger tight.
- 3) Using the two remaining button heads attach the rack upright in the center and on top of the leg assembly.
- 4) Square up the rack and tighten all the screws.
- 5) Place the cloth bag into the upright. Seat the strapping handles into the upright flares.
- 6) To clean your rack, use a damp cloth and dry it thoroughly. If a touch-up is ever necessary, remove any dirt or rust with steel wool and re-coat with a "Pledge" like wax product.

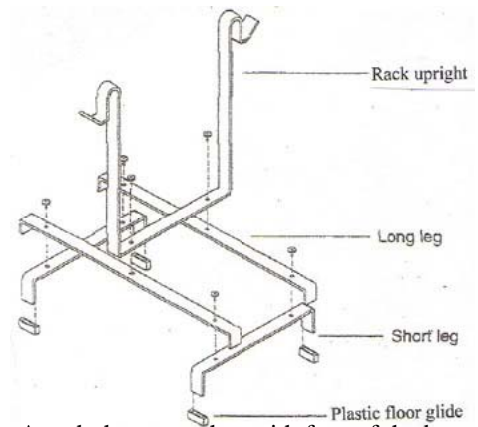

It is important that your rack is assembled correctly. If the unit is assembled or used incorrectly, it could become unstable and collapse, possibly causing injury.

**Limited Warranty:** This product is warranted to be free of material defects for a period of five year from the date of purchase. Customer's exclusive remedy shall be the repair or replacement of the defective product and shall be subject to the following conditions: (1) notice of any defect is received by Enclume within the warranty period and (2) customer returns the defective product to Enclume Design Products, Inc. , 24 Colwell St. , Port Hadlock, WA 98339, *postage prepaid* within 20 days following a return authorization number (which may be obtained by telephoning the number at the bottom of this instructions) being provided to the customer by Enclume. There are no other warranties, expressed or implied. **THERE ARE NO WARRANTIES OF MERCHANTABILITY OR FITNESS FOR A PARTICULAR PURPOSE. ENCLUME SPECIFICALLY DISCLAIMS ANY AND ALL INCIDENTAL OR CONSEQUENTIAL DAMAGES ARISING OUT OF THE PURCHASE OR USE OF ENCLUME'S PRODUCTS.**



If you need help, please call 1-877-ENCLUME

**Enclume Design Products, Inc.**

24 Colwell Street, Port Hadlock, WA. 98339

Phone 360-385-6100 • Fax 360-385-6156

[www.enclume.com](http://www.enclume.com)